

HD3C Swinging beam trolley for hand operated crane

1.100kg – 5.300kg
lifting capacity

Address:

Parelhoenweg 2
4791 PA Klundert
The Netherlands

Contact:

T +31 168 385 225
E info@vanleusden.com
I www.vanleusden.com



**RELIABLE HOISTING
SOLUTIONS,
ENGINEERED
FOR EXTREME
APPLICATIONS.**

HD3C Swinging beam trolley for hand operated crane

1.100kg – 5.300kg lifting capacity

Designed and manufactured according to:

- EC machinery directive 2006/42/EC
- EN13157
- Manufactured in the Netherlands

Standard features:

- Smooth running along crane gantry by flexible suspension system by ball joint
- Ball joint made from S355, suitable for welding
- Fixed suspension set for specified crane gantry beam width
- Wheel break support and anti-tilt device integrated
- Trolley wheels with life time lubricated bearings
- Suitable for all types of beams
- Surface treatment trolley electric galvanized chassis, wheels and wheel shafts. Suspension set in Zinc primer + top coat

Optional:

- Mounting plate for bolt suspension to crane girder
- Rubber buffers mounted on trolley
- Stainless steel trolley wheels
- Special side plates to increase dimension "E"
- 3.1 load test certificate
- Special surface protection according ISO 12944
- Stainless steel execution
- Customized solutions
- General arrangement drawing in 2D dwg and 3D step file

Technical information:

1. Maximum span (S) is 8m for all capacities
2. For crane with an outreach larger than (T) contact us or your local supplier
3. Always specify your girder type, for production of the suitable mounting plate.
4. Maximum INP profile restriction for 11kN = INP300, 22kN = INP360, 33kN = INP400, 52kN = INP450

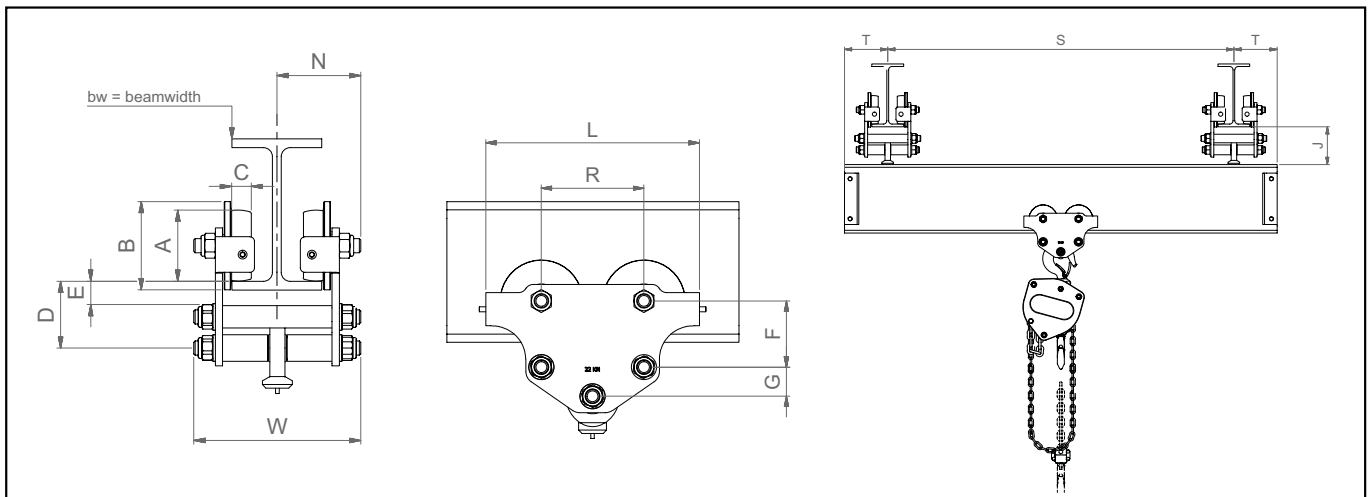

Capacity kg	Article number	Chassis	Fixed beam with in range mm	Suspension GKDO ¹	Weight kg	Dimensions												
						A	B	C	L	T	J	W	R	D	E	F	G	N
1.100	82000-01110	11 kN	55-120	20	6	60	75	18	190	125	100	BW + 70	99	60	20	60	30	65
	82000-01120		121-240	25							105							
	82000-01130		241-305	30							110							
2.250	82000-02210	22 kN	74-113	25	12	80	100	22	255	150	120	BW + 85	123	75	27	80	35	65
	82000-02220		114-210	30							125							
	82000-02230		211-305	35							135							
3.350	82000-03310	33 kN	90-131	30	20	100	120	25	300	175	140	BW + 105	144	90	35	100	40	70
	82000-03320		132-220	35							150							
	82000-03330		221-305	40							160							
5.300	82000-05210	52 kN	106-131	35	32	125	150	30	375	200	180	BW + 120	174	117	40	120	60	100
	82000-05220		132-210	40							185							
	82000-05230		211-310	45							195							

¹ GKDO: Spherical plain bearings and rod ends